

# Use & Care

**G U I D E**

## Side By Side Refrigerator/Freezer

A Note to You .....	2
Refrigerator Safety ....	3
Parts and Features ...	4
Installing Your Refrigerator .....	7
Using Your Refrigerator .....	12
Caring for Your Refrigerator .....	27
Food Storage Guide .....	30
Troubleshooting Guide .....	32
Requesting Assistance or Service .....	39
Index .....	40
Warranty .....	44

**1-800-253-1301**

Call our Consumer Assistance  
Center anytime with  
questions or comments.



# A NOTE TO YOU

## Thank you for buying a WHIRLPOOL® appliance.

Because your life is getting busier and more complicated, WHIRLPOOL refrigerators are easy to use, save time, and help you manage your home better. To ensure that you enjoy years of trouble-free operation, we developed this Use and Care Guide. It is full of valuable information about how to operate and maintain your appliance properly and safely. Please read it carefully.

Also, please complete and mail the **Product Registration Card** provided with your appliance. The card helps us notify you about any new information for your appliance.

## Record your model's information

Write down the following information about your refrigerator to better help you obtain assistance or service if you ever need it. You will need to know your complete model number and serial number. You can find this information on the model and serial number plate.

Dealer name \_\_\_\_\_ Model number \_\_\_\_\_  
Address \_\_\_\_\_ Serial number \_\_\_\_\_  
Phone number \_\_\_\_\_ Purchase date \_\_\_\_\_

(See "Parts and Features" on pages 4-6 for model and serial number label location.)

**Keep this book and your sales slip together for future reference.**

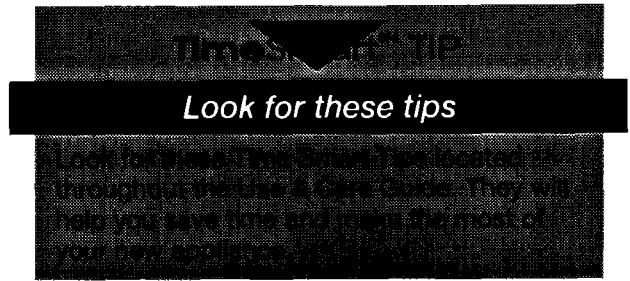

**Call us toll-free anytime with comments or questions at our Consumer Assistance Center: 1-800-253-1301**

# REFRIGERATOR SAFETY

## Your safety is important to us.

This guide contains safety statements under a warning symbol. This symbol alerts you to such dangers as fire, electrical shock, burns, and personal injury. Please pay special attention to this symbol and follow any instructions given.



## IMPORTANT SAFETY INSTRUCTIONS

### **! WARNING**

To reduce the risk of fire, electrical shock, or injury when using your refrigerator, follow these basic precautions:

- Read all instructions before using the refrigerator.
  - Child entrapment and suffocation are not problems of the past. Junked or abandoned refrigerators are still dangerous ... even if they will "just sit in the garage a few days."  
If you are getting rid of your old refrigerator, do it safely. Please read the enclosed safety booklet from the Association of Home Appliance Manufacturers. Help prevent accidents.
  - Never allow children to operate, play with, or crawl inside the refrigerator.
  - Never clean refrigerator parts with flammable fluids. The fumes can create a fire hazard or explosion.
- FOR YOUR SAFETY ●
- DO NOT STORE OR USE GASOLINE OR OTHER FLAMMABLE VAPORS AND LIQUIDS IN THE VICINITY OF THIS OR ANY OTHER APPLIANCE. THE FUMES CAN CREATE A FIRE HAZARD OR EXPLOSION.

**- SAVE THESE INSTRUCTIONS -**

## Help us help you

Please:

- Install and level the refrigerator on a floor that will hold the weight and in an area suitable for its size and use.
- Do not install the refrigerator near an oven, radiator, or other heat source.
- Do not use the refrigerator in an area where the temperature will fall below 55°F (13°C).
- Keep the refrigerator out of the weather.
- Connect the refrigerator only to the proper kind of outlet, with the correct electrical supply and grounding. (See "Electrical Requirements" on page 7 or refer to the Electrical Requirements and Grounding Instructions Sheet in your Literature Package.)
- Do not load the refrigerator with food before it has time to get properly cool. (See "Setting the controls" on page 12.)
- Use the refrigerator only for the uses described in this manual.
- Properly maintain the refrigerator.
- Be sure the refrigerator is not used by anyone unable to operate it properly.

# PARTS AND FEATURES

This section contains illustrations of your refrigerator. Use them to become familiar with the location of all the parts and features. Page references are included for your convenience.

**NOTE:** This manual covers several different models. The model you have purchased may have all or some of the parts and features shown here, and they may not match the illustration exactly.

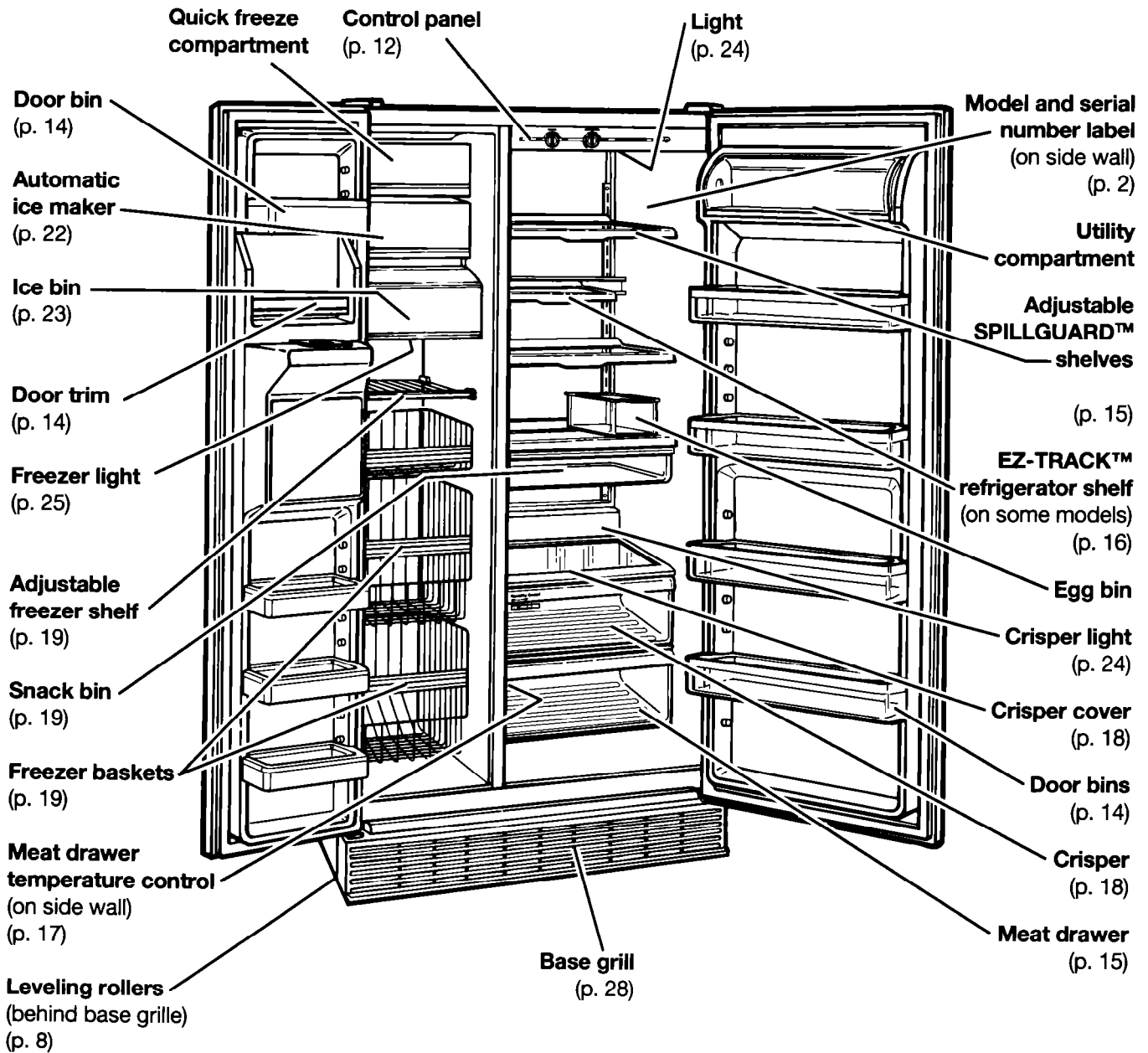

**NOTE:** This manual covers several different models. The model you have purchased may have all or some of the parts and features shown here, and they may not match the illustration exactly.

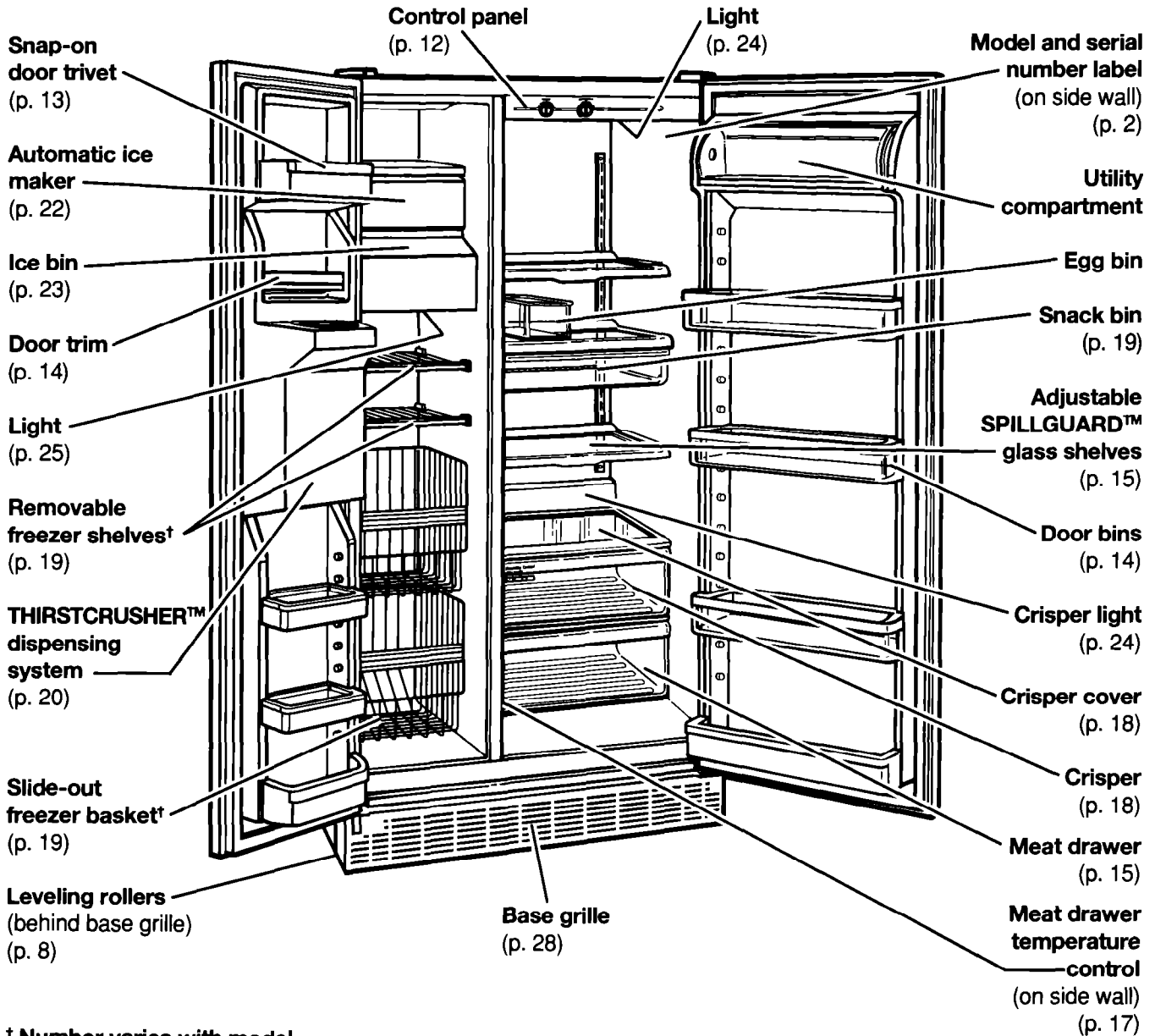

† Number varies with model

# PARTS AND FEATURES

**NOTE:** This manual covers several different models. The model you have purchased may have all or some of the parts and features shown here, and they may not match the illustration exactly.

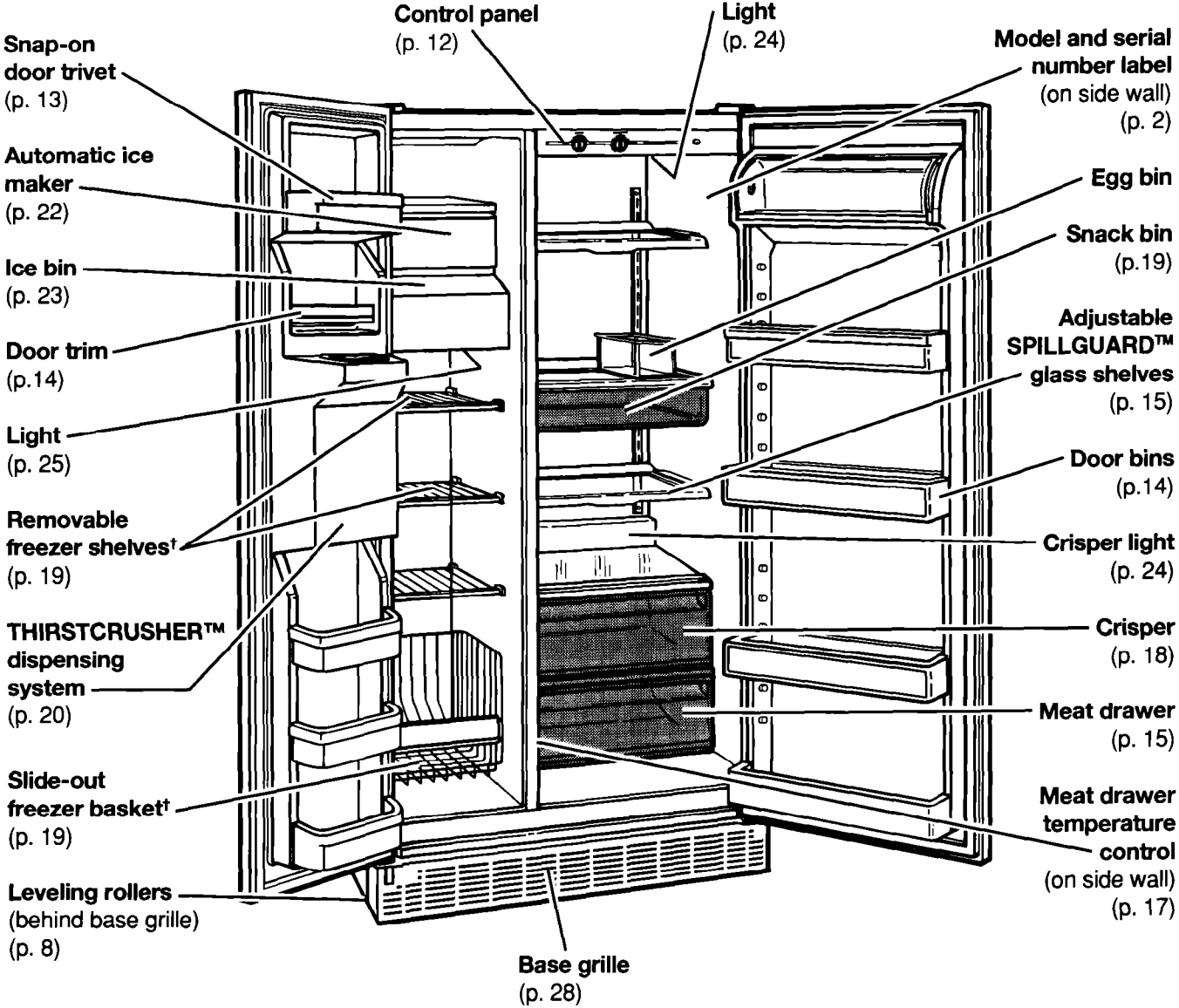

† Number varies with model

# INSTALLING YOUR REFRIGERATOR

It is important to prepare your refrigerator for use. This section tells you how to clean it, connect it to a power source, install it, and level it.

## UNPACKING YOUR REFRIGERATOR

### Removing packaging materials

Remove tape and any labels from your refrigerator before using (except the model and serial number label).

To remove any remaining tape or glue, rub the area briskly with your thumb. Do not use sharp instruments, rubbing alcohol, flammable fluids, or abrasive cleaners. These products can damage the surface of your refrigerator. For more information, see "Important Safety Instructions" on page 3.

**NOTE:** Do not remove any permanent instruction labels inside your refrigerator, or the Tech Sheet that is fastened under the front.

### Cleaning before use

After you remove all of the packaging materials, clean your refrigerator before using it if needed. See the cleaning instructions on page 27 for more information.



TimeSaver TIP

### Easy clean up

Tape or glue residue can be easily removed by rubbing a small amount of liquid dish soap over the residue with your fingers. Rinse immediately and dry.

## ELECTRICAL REQUIREMENTS

Before you move your refrigerator into its final location, it is important to make sure you have the proper electrical connection.

### Recommended Grounding Method

A 115 Volt, 60 Hz., AC only 15 or 20 ampere fused, grounded electrical supply is required. It is recommended that a separate circuit serving only your refrigerator be provided. Use an outlet that cannot be turned off by a switch. Do not use an extension cord. Refer to the Electrical Requirements and Grounding Instructions Sheet in your Literature Package for more details.

**NOTE:** Before performing any type of installation, cleaning, or removing a light bulb, turn the Refrigerator Control to OFF and then disconnect the refrigerator from the electrical source. When you are finished connect the refrigerator to the electrical source and reset the Refrigerator Control to the desired setting.

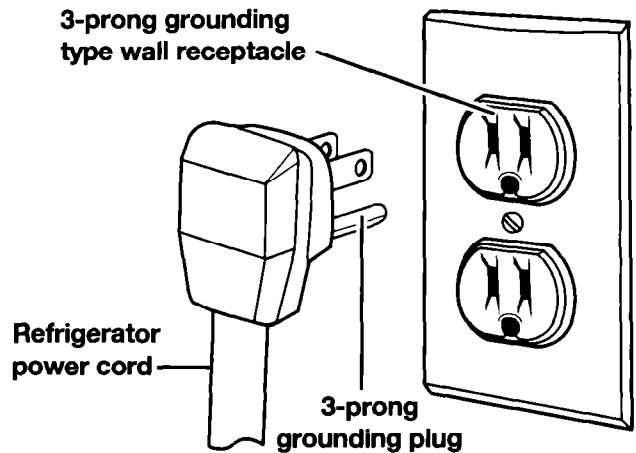

## SPACE REQUIREMENTS

To ensure proper ventilation for your refrigerator, allow for a ½-inch (1.25 cm) space on each side and at the top. For models that have ice and water dispensers, make sure you leave some extra space at the back to allow for the water line connections.

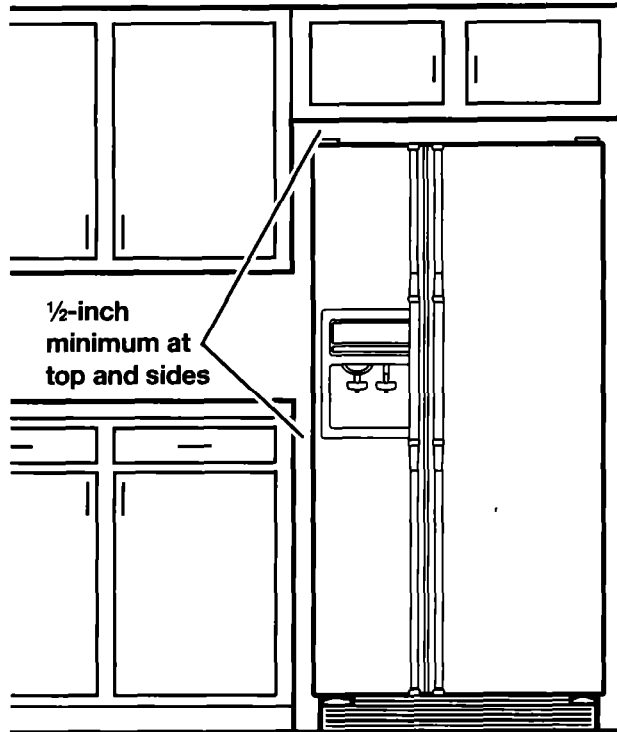

## LEVELING

Move the refrigerator into its final position. Use a level and check that the refrigerator is level.

**NOTE:** If your refrigerator has an automatic ice maker, do this before attaching the ice maker to a water supply. If you move the refrigerator after the water line has been hooked up you may loosen or disconnect the fittings.

Your refrigerator has two leveling screws, one on each side.

### To level your refrigerator:

1. Check to see if the rear of the refrigerator is level. Shimming may be necessary if your refrigerator is placed on an uneven surface.
2. Adjust the front of the refrigerator by removing the base grille (see page 28).
3. Turn the leveling screw clockwise on the side that you want to raise. If you want to lower that side, turn the screw counterclockwise.

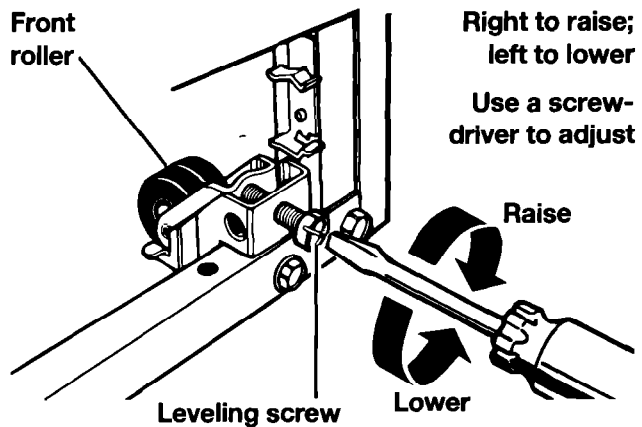

## LEVELING (CONT.)

4. Make sure that the doors are even. If the freezer door is lower than the fresh food door, turn the leveling screw on the freezer side clockwise. If the fresh food door is lower, turn the leveling screw on that side clockwise.
5. Replace the base grille.
6. If you are not hooking up an ice maker, connect the refrigerator to the electrical supply after leveling, and then see page 12.

## ATTACHING THE ICE MAKER TO A WATER SUPPLY

**Read all directions carefully before you begin.**

**! WARNING**



**Electrical Shock Hazard**

**Unplug the refrigerator before installing ice maker.**

**Failure to do so can result in death or electrical shock.**

**NOTE:** Your appliance dealer has a kit available with a 1/4-inch saddle type shut-off valve, a union, and copper tubing. Before purchasing, make sure a saddle type valve complies with your local plumbing codes. Do not use a piercing type or 3/16-inch saddle valve which reduces water flow and clogs more easily.

### Cold water supply

The ice maker water valve contains a flow washer which is used as a water pressure regulator. The ice maker needs to be connected to a cold water line with water pressure limitations of 20-120 psi. If a problem occurs, call your utility company.

### IMPORTANT:

- It may take up to 24 hours for your ice maker to begin producing ice.
- If operating the refrigerator before installing the water connection, turn ice maker to the OFF position to prevent operation without water.
- All installations must be in accordance with local plumbing code requirements.

### IMPORTANT:

- Use copper tubing only and check for leaks.
- Install ice maker tubing in areas where temperatures are above freezing.

### Tools required:

- Standard screwdriver
- 7/16-inch and 1/2-inch open-end wrenches or two adjustable wrenches
- 1/4-inch nut driver
- 1/4-inch drill bit
- Hand drill or electric drill (properly grounded)

**INSTALLATION IS NOT WARRANTED  
BY REFRIGERATOR OR ICE MAKER  
MANUFACTURER.**

## ATTACHING THE ICE MAKER TO A WATER SUPPLY (CONT.)

### Connecting to water line

1. Find a ½-inch to 1¼-inch vertical COLD water pipe near the refrigerator.

**NOTE:** Horizontal pipe will work, but the following precaution must be taken: Drill on the top side of the pipe, not the bottom. This will help keep water away from the drill. This also keeps normal sediment from collecting in the valve.

2. Measure from connection on rear of refrigerator to water pipe. Add 7 feet (2.1 m) to allow for moving refrigerator for cleaning. This is the length of ¼-inch O.D. copper tubing you will need for the job (length from connection to water pipe PLUS 7 feet [2.1 m]). Be sure both ends of copper tubing are cut square.
3. Turn OFF main water supply. Turn ON nearest faucet long enough to clear line of water.
4. Using a grounded drill, drill a ¼-inch hole on the cold water pipe you have selected.
5. Fasten shut-off valve to cold water pipe with pipe clamp. Be sure outlet end is solidly in the ¼-inch drilled hole in the water pipe and that washer is under the pipe clamp. Tighten packing nut. Tighten the pipe clamp screws carefully and evenly so washer makes a watertight seal. Do not overtighten or you may crush the copper tubing, especially if soft (coiled) copper tubing is used. Now you are ready to connect the copper tubing.
6. Slip compression sleeve and compression nut on copper tubing as shown in diagram. Insert end of tubing into outlet end squarely as far as it will go. Screw compression nut onto outlet end with adjustable wrench. Do not overtighten. Turn ON main water supply and flush out tubing until water is clear. Turn OFF shut-off valve on the water pipe. Coil copper tubing.

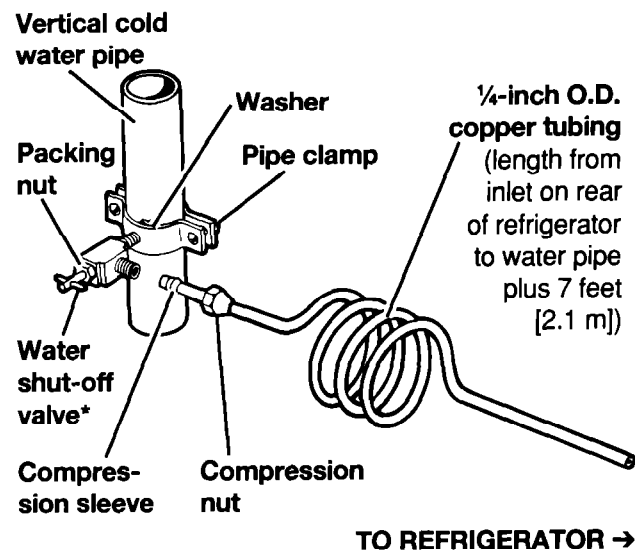

\* Controls water supply

# ATTACHING THE ICE MAKER TO A WATER SUPPLY (CONT.)

## Connecting to refrigerator

**NOTE:** The first step for connecting the water line to your refrigerator is different depending on the type of water valve provided with your refrigerator. See the diagrams at right to determine the style of valve you have. (On kit models, assemble water valve to refrigerator per kit instructions.)

**1. For style #1,** disconnect the tube clamp on the back of the product and insert the copper tubing through the clamp, as shown at the right. Remove the tape label from the valve inlet and insert copper tubing until it bottoms out (approximately  $\frac{3}{4}$ -inch). Tighten nut by hand as much as possible; then turn the nut an additional  $\frac{1}{2}$  turn using a wrench. Do not overtighten. Re-attach the tube clamp and tube to the back of the cabinet. Skip to step 2.

Style #1 valve

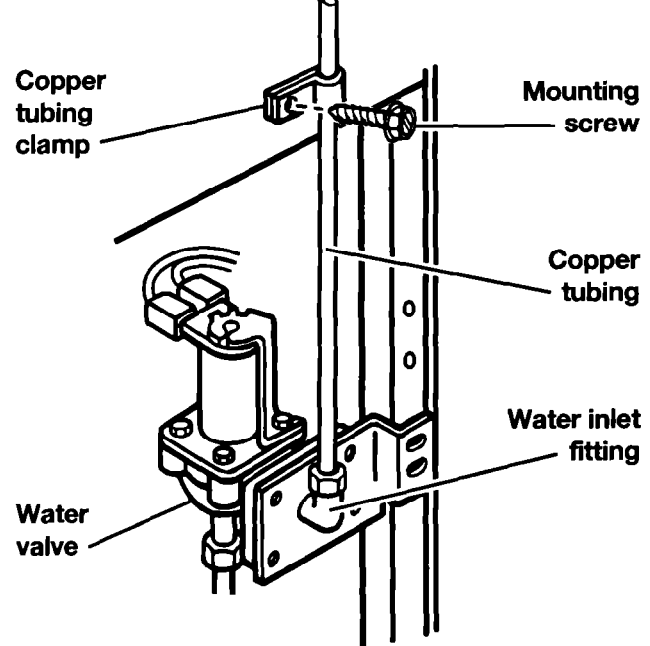

**For style #2,** disconnect the tube clamp on the back of the product and insert copper tubing through the clamp as shown at the right. Attach the copper tube to the valve inlet using a compression nut and sleeve as shown. Tighten the compression nut. Do not overtighten. Reattach the tube clamp and tube to the back of the cabinet. Move to step 2.

Style #2 valve

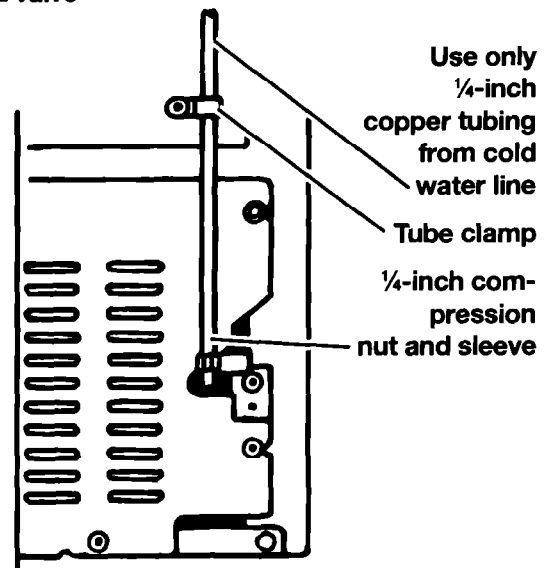

**2. Turn shut-off valve ON. CHECK FOR LEAKS. TIGHTEN ANY CONNECTIONS (INCLUDING CONNECTIONS AT THE VALVE) OR NUTS THAT LEAK.**

**3.** The ice maker is equipped with a built-in water strainer. If local water conditions require periodic cleaning or a well is your source of water supply, a second water strainer should be installed in the  $\frac{1}{4}$ -inch water line. Obtain a water strainer from your nearest appliance dealer. Install at either tube connection.

**4.** After installation, connect the refrigerator to the electrical supply and push it back into place.

**5.** Check to make sure the refrigerator is level. (See "Leveling" on page 8.)

# USING YOUR REFRIGERATOR

To obtain the best possible results from your refrigerator, it is important that you operate it properly. This section tells you how to set the controls, remove and adjust the features in your refrigerator, and how to save energy.

## SETTING THE CONTROLS

When you first install your refrigerator, set the Refrigerator Control at 3 and the Freezer Control at B. Give your refrigerator time to cool down completely before adding food. It is best to wait 24 hours before adding food.

**IMPORTANT:** If you add food before the refrigerator has cooled completely, your food may spoil. Turning the Refrigerator and Freezer controls to a higher than recommended setting will not cool the compartments any faster.

### How the controls work

There are two controls in your refrigerator compartment. Knowing how each works will help you set the controls properly for your own household conditions.

The Refrigerator Control functions as the thermostat

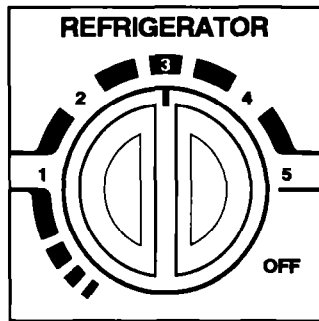

for the entire product (fresh food and freezer sections). The higher the number setting, the longer the compressor will run to keep the temperature colder.

**NOTE:** Your product will **not** cool when the Refrigerator Control is set to OFF.

The Freezer Control functions as an air flow director.

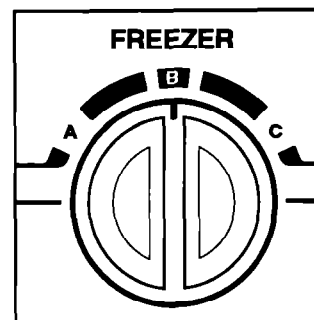

Setting "A" will direct more of the cold air into the fresh food section, while setting "C" will direct more of the cold air into the freezer section. The cold air travels from the freezer compartment through the **top vent**, into your fresh food section

(see the diagram Ensuring Proper Air Circulation on page 13).

Hold your hand in front of the **top vent** (see the diagram Ensuring Proper Air Circulation on page 13) and adjust the Freezer Control to feel the difference in air flow.

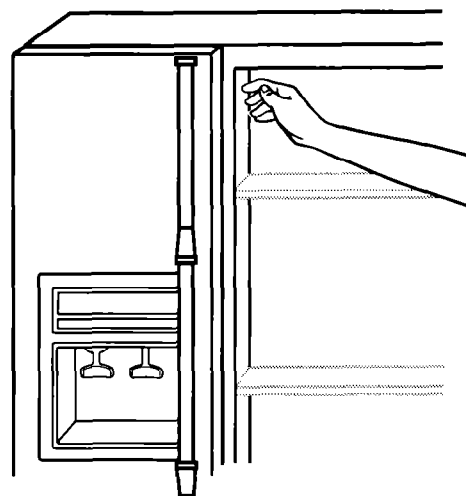

### Time-Saver TIP

#### Stay cool

Overcrowding in your refrigerator can cause food temperatures to vary. Arrange foods on the shelves so the air can circulate freely to maintain the desired temperature.

## ENSURING PROPER AIR CIRCULATION

In order to ensure proper temperatures, you need to permit air flow between the two sections. As shown in the illustration, cold air enters the bottom of the freezer section (A) and moves up. It then enters the fresh food section through the **top vent** (B). Air returns to the freezer through the vent at (D).

**Do not block any of these vents** with food such as soda, cereal, bread, etc. If the vents are blocked, air flow will be prevented and the temperature controls will not function properly.

To adjust the air control vent C, see "Adjusting the Meat Drawer Temperature" on page 17.

**IMPORTANT:** Because air circulates between both sections, any odors formed in one section will transfer to the other. You must thoroughly clean both sections to eliminate odors. To prevent odor transfer from food, wrap or cover foods tightly.

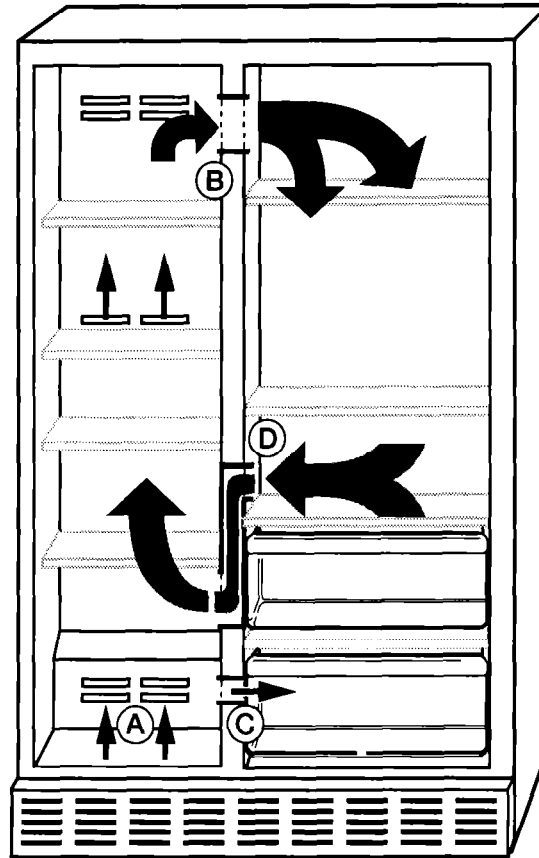

## REMOVING THE SNAP-ON DOOR TRIVET (ON SOME MODELS)

The door trivets may be removed for easier cleaning.

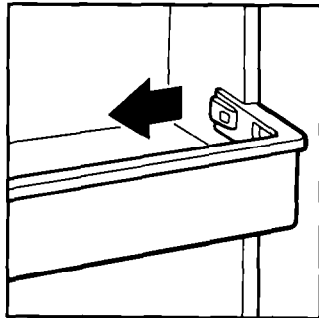

**To remove the trivet**, first remove all items from the shelf. Then push in slightly and pull out on each side of the inside tab and lift the trivet straight out.

**To replace the trivet**, line up the ends of the trivet with the buttons on the sides of the door liner. Push the trivet straight back until it snaps into place.

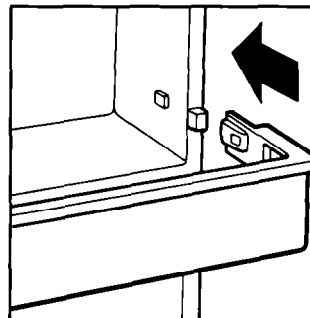

## REMOVING THE DOOR TRIM (DISPENSER AREA) (ON SOME MODELS)

The trim above the dispenser area may be easily removed for convenient cleaning. **To remove the trim piece**, first remove all items from the shelf. Then simply pull straight up on each end of the trim piece.

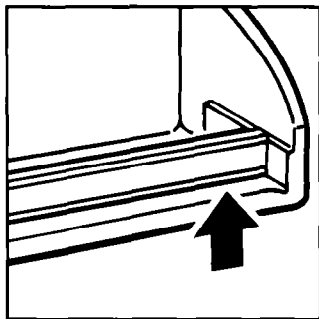

**To replace the trim**, line up each end of the trim above the trim pocket opening in the door liner wall. Then push the trim straight down on both sides until it stops.

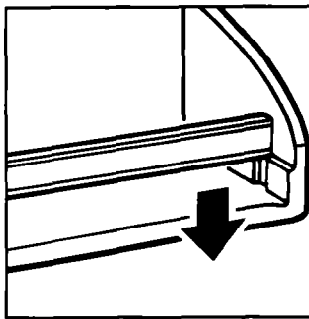

## ADJUSTING THE DOOR BINS

The door bins are removable for easy cleaning and adjusting. **To remove the bin**, simply lift the bin up and pull straight out. **To replace the bin**, slide it in above the desired support button and push down until it stops.

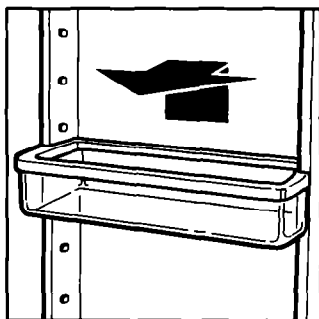

## ADJUSTING THE SPILLGUARD™ REFRIGERATOR SHELVES

The shelves in your refrigerator are adjustable to match the way you use them. Glass shelves are strong enough to hold bottles, milk, and other heavy food items.

**To remove a shelf,** first remove all items from the shelf. Then tilt up the front of the shelf and lift it at the back. Pull the shelf straight out.

**To replace a shelf,** guide the rear shelf hooks into the slots of the shelf supports on the back liner of the refrigerator. Tilt the front of the shelf up until the rear hooks drop into the slots and then lower the front of the shelf into position.

**To slide shelf out:**

- Carefully pull front of shelf toward you.

**To slide shelf in:**

- Push shelf in until it stops.

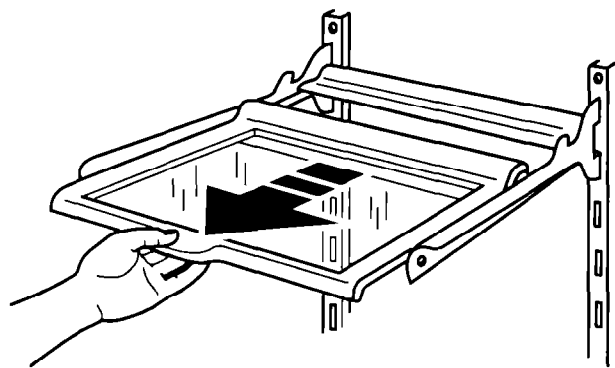
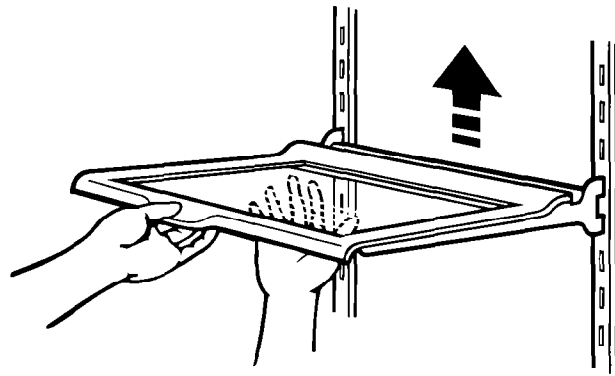

**Timesmart™ TIP**

**Quick and Easy**

Store similar food items together in your refrigerator and freezer. This will make them easy to find and cut down the amount of time the doors are open.

## REMOVING THE MEAT DRAWER AND COVER

**To remove the meat drawer:**

- Slide the meat drawer straight out to the stop.
- Lift the front slightly and slide it out the rest of the way.
- Replace in the reverse order.

**To remove the cover:**

- Remove the meat drawer and the crisper.
- Lift the front of the cover off of the supports and remove it by pulling up and out.

**To replace the cover:**

- Fit the back of the cover into the notch supports on the walls of the refrigerator and lower it into place.
- Replace the meat drawer and crisper.

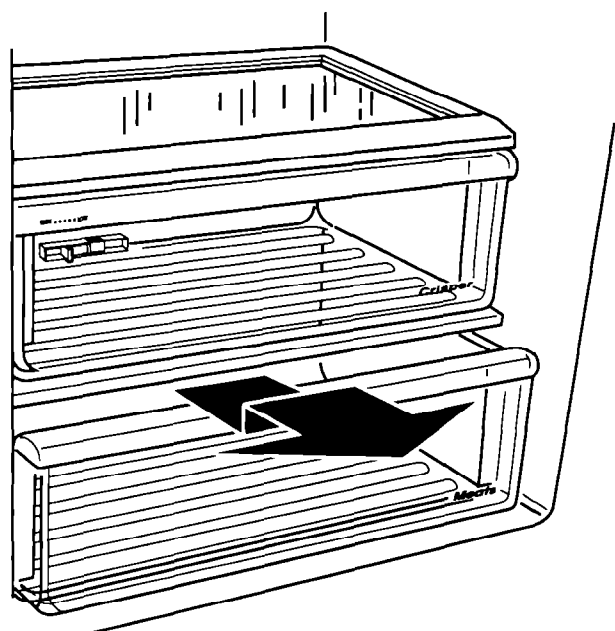

## ADJUSTING THE EZ-TRACK™ REFRIGERATOR SHELF (ON SOME MODELS)

The EZ-TRACK shelf slides from side to side for more flexible storage in your refrigerator.

**To slide the shelf from side to side,** lift up on the front of the shelf and slide to the desired location. Then lower the shelf to the level position.

**NOTE:** You do not have to remove small items from the shelf before moving it from side to side. You may need to remove larger items.

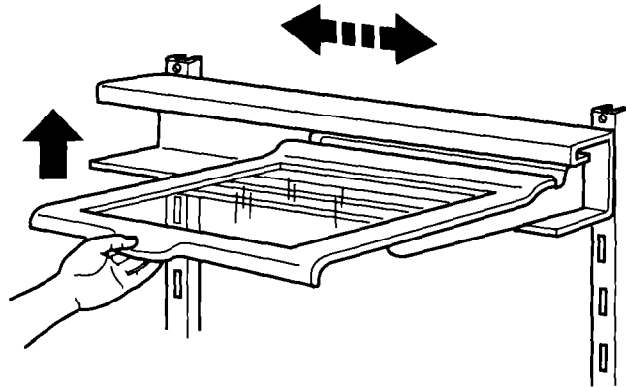

**To remove the shelf,** take all items off of the shelf and hold the back of the shelf with one hand. Lift the front of the shelf with the other hand to a 45° angle and lower it slightly to release it from the track. Then pull the shelf straight out.

**NOTE:** The shelf is heavy and must be removed using both hands.

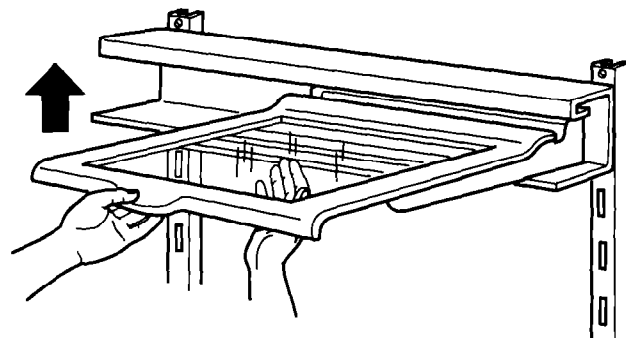

**To remove the shelf track,** lift both sides of the track slightly and pull straight out.

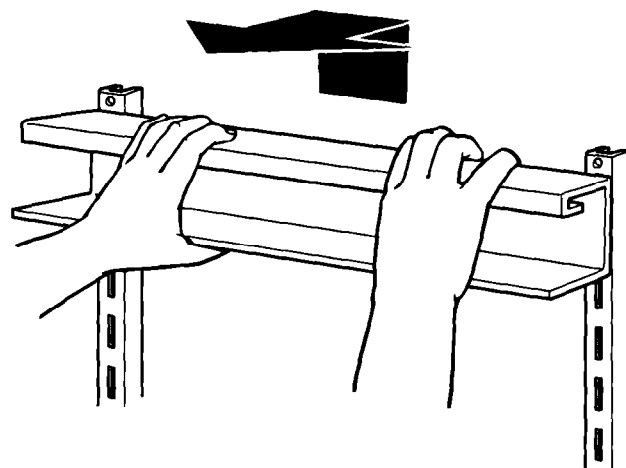

## ADJUSTING THE EZ-TRACK™ REFRIGERATOR SHELF (CONT.)

To replace the shelf track, guide the track hooks into the shelf support slots on the back wall.

**NOTE:** Make sure that both sets of track hooks are in the slots and that the slots are parallel with each other.

Then push the track back and down securely into the shelf supports.

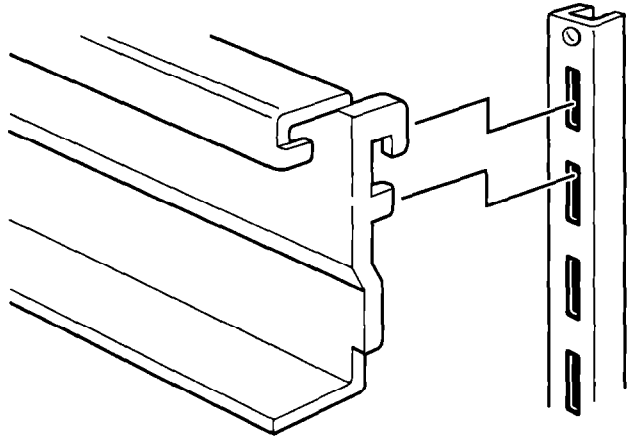

To reinstall the shelf, hold the shelf at the front and tip the front at a 45° angle to the track. Insert both of the rear shelf slides into the upper channel of the track and lower the front into place.

**NOTE:** Make sure that both of the rear shelf slides are securely in the track before letting go of the shelf.

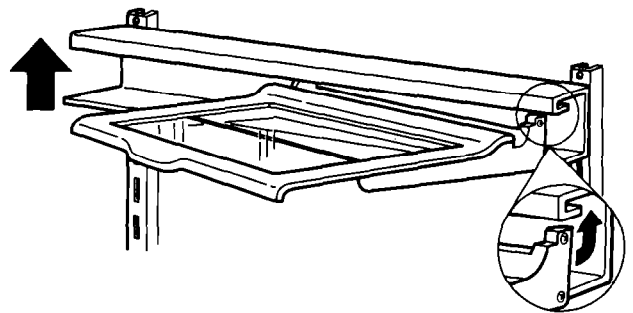

## ADJUSTING THE MEAT DRAWER TEMPERATURE

The meat drawer is cooled from cold air that flows in from the freezer compartment through a vent in the wall of the refrigerator (See "Ensuring Proper Air Circulation" vent C on page 13.) This helps to keep the meat drawer colder than the rest of the refrigerator for better storage of meats.

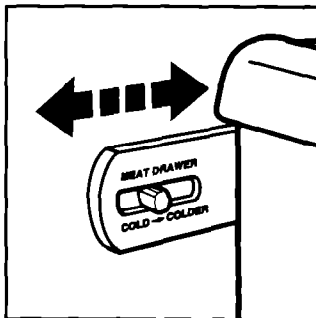

To adjust the temperature, slide the control from side to side to let more or less cold air into the meat drawer. Set the control toward Cold for a slightly cooler temperature, or toward Colder for a much cooler temperature.

**NOTE:** Putting the control on the coldest setting may cause freezing or ice crystals, depending on the items you have in the meat drawer.

## REMOVING THE CRISPER AND CRISPER COVER

The crisper and its cover are designed for easy removal and cleaning.

**To remove the crisper**, slide it straight out to the stop and lift the front. Then slide it out the rest of the way.

**Replace the crisper** in the reverse order.

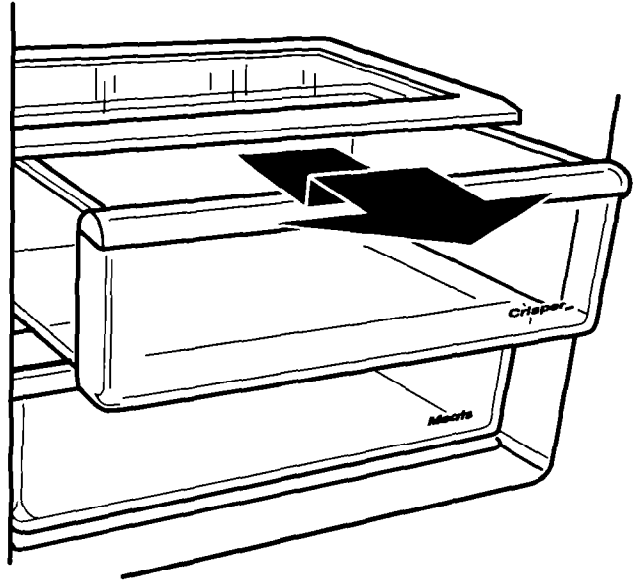

**To remove the cover**, hold it firmly with both hands, lift the front out of the supports and pull it up and out.

**To replace the cover**, fit the back of the cover into the notch supports on the walls of the refrigerator and lower the front into place.

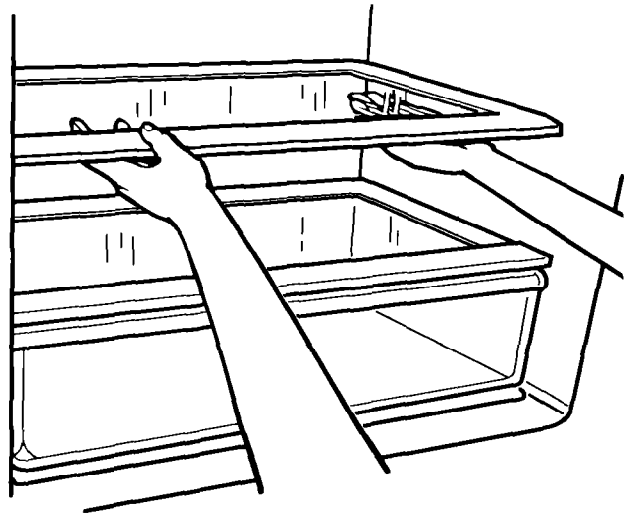

## REMOVING THE SNACK BIN (ON SOME MODELS)

The snack bin provides a convenient place to store raisins, nuts, spreads, and other small items at normal refrigerator temperatures.

**To remove the snack bin**, slide the snack bin straight out to the stop, lift the front, and slide the bin out the rest of the way.

**Replace** the snack bin in the reverse order.

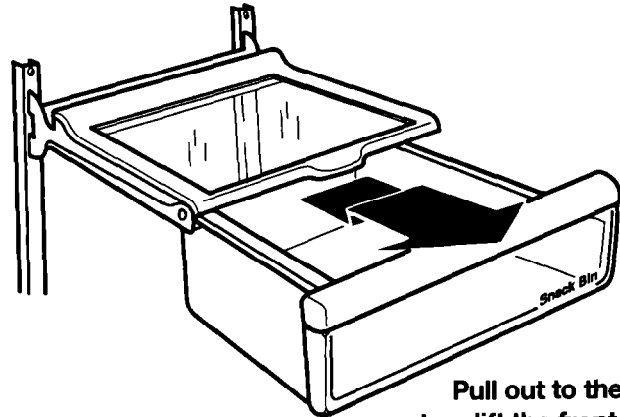

**Pull out to the stop, lift the front, and pull again**

## REMOVING THE FREEZER BASKET (PLASTIC BIN ON SOME MODELS)

The freezer basket can be used to store bags of frozen fruits and vegetables that can slide off freezer shelves.

**For easy removal** of the freezer basket, slide it out to the stop, lift the front, and slide it out the rest of the way.

**To replace the basket**, position it on the slides,

making sure that the wire stops clear the front of the slides, and slide it in all the way.

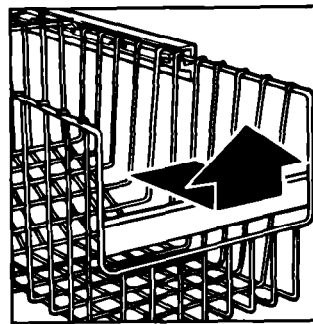

## REMOVING THE FREEZER SHELF

The freezer shelf is removable for easy cleaning, or to create more open space in the freezer compartment for storage of large or bulk items.

**To remove the shelf**, lift the shelf off of the sup-

ports and slide out of the shelf support holes. **Replace** in the reverse order.

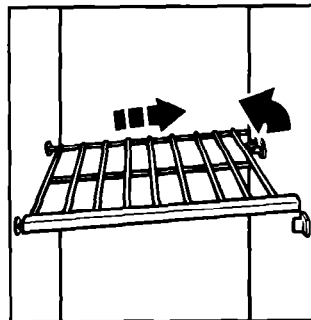

# USING THE THIRSTCRUSHER™ DISPENSING SYSTEM

## ⚠ WARNING



### Cut Hazard

Use a sturdy glass when dispensing ice or water.

Failure to do so can result in cuts.

## The ice dispenser

The ice dispenses from the ice maker storage bin located in the freezer. When you press the dispenser bar, a trapdoor opens in a chute between the dispenser and the ice bin. The ice moves from the bin and falls through the chute. When you release the dispenser bar, a buzzing sound may be heard for a few seconds as the trapdoor closes.

For crushed ice, cubes are crushed before being dispensed. This may cause a slight delay when dispensing crushed ice. Noise from the ice crusher is normal, and pieces of ice may vary in size.

When changing from CRUSHED to CUBED, a few ounces of crushed ice will be dispensed along with the first cubes.

**REMEMBER:** The dispenser will not operate when the freezer door is open.

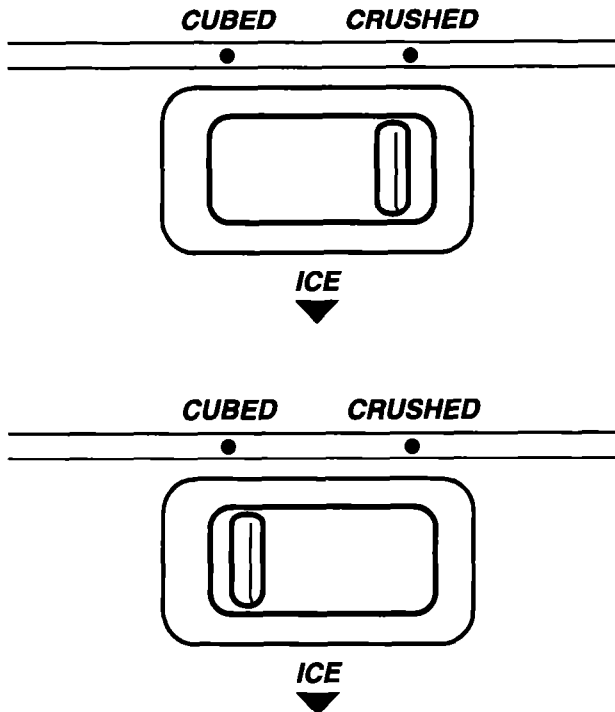

# USING THE THIRSTCRUSHER™ DISPENSING SYSTEM (CONT.)

## The ice dispenser (cont.)

To dispense ice, first select CUBED or CRUSHED by moving the Ice Selector Switch to the desired setting. Then press a **sturdy** glass against the ice dispenser bar. Be sure to hold the glass close to the dispenser opening so ice does not fall outside of the glass. Remove the glass to stop dispensing. If you are going to need a large amount of ice, take it directly from the ice bin in the freezer. Do not use the dispenser.

**NOTE:** The first few batches of ice may have an off-flavor due to the new plumbing and parts. Throw this ice away.

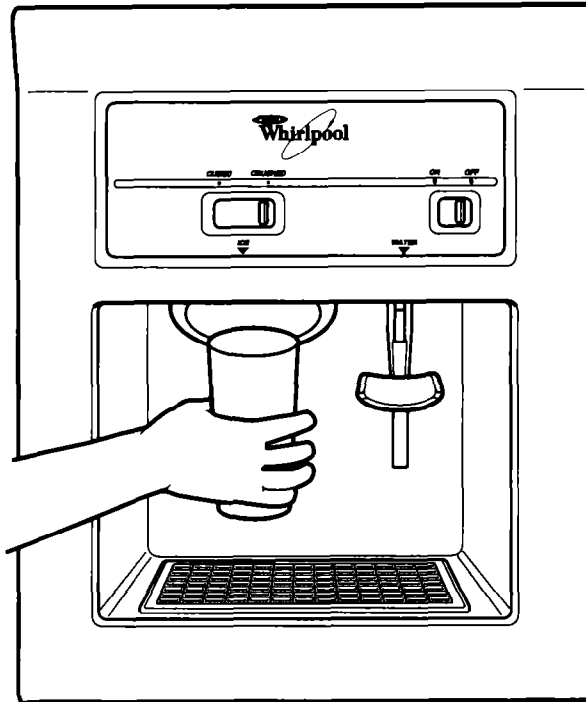

## The water dispenser

The water for the dispenser comes from a tank behind the meat drawer. It holds approximately 1½ quarts (1.5 L).

To start the water dispenser when the refrigerator is first hooked up, press the water dispenser bar with a glass or jar until you draw and discard two or three quarts (1.9 to 2.8 L). It will take one to three minutes for water to begin dispensing. This first water that you draw and discard will fill the tank and pipes. Allow several hours to cool a new tankful.

**NOTE:** The small tray beneath the dispenser is designed to evaporate **small** drips. **Do not** pour water into the tray because there is no drain in it.

**To dispense water**, press a **sturdy** glass against the water dispenser bar. Remove the glass to stop dispensing.

**REMEMBER:** Dispense enough water every week to maintain a fresh water supply in the tank.

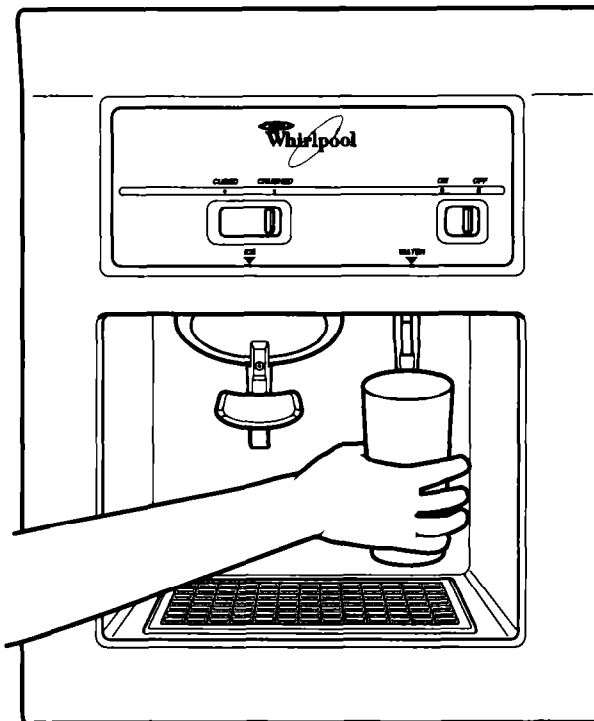

## USING THE THIRSTCRUSHER™ DISPENSING SYSTEM (CONT.)

### The dispenser light

To turn on the night light, slide dispenser LIGHT switch to the left. See page 25 for directions on changing the dispenser light bulb.

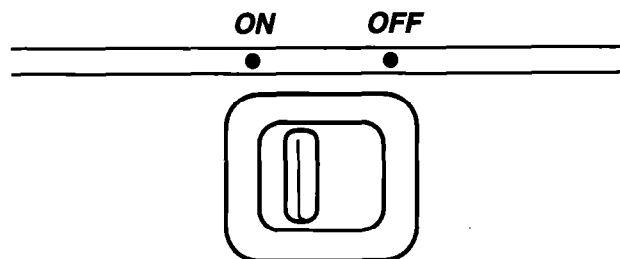

## USING THE AUTOMATIC ICE MAKER

Read the information below to learn how to operate your ice maker. Before you turn the ice maker on, be sure that it is attached to a water supply. Instructions for the ice maker water supply hookup are on pages 9-11 of this manual.

- The ON/OFF lever is a wire signal arm. Push the arm down to start making ice automatically, and push it up to shut off the ice maker.
- It is normal for the ice to be attached at the corners. It will break apart easily.
- The ice maker will not operate until the freezer is cold enough to make ice. This can take as long as overnight.
- If ice is not being made fast enough and more ice is needed, turn the Refrigerator Control toward a higher number in half number steps. (For example, if the control is at 3, move it to between 3 and 4.) Wait 24 hours and, if necessary, gradually turn the Freezer Control toward C, waiting 24 hours in between each increase.

### REMEMBER:

- The quality of your ice will be only as good as the quality of the water supply that the ice maker is hooked up to.
- Avoid connecting the ice maker to a softened water supply. Water softener chemicals (such as salt) can damage the ice maker mold and lead to poor quality ice. If a softened water supply cannot be avoided, make sure the water softener is operating properly and is well maintained.

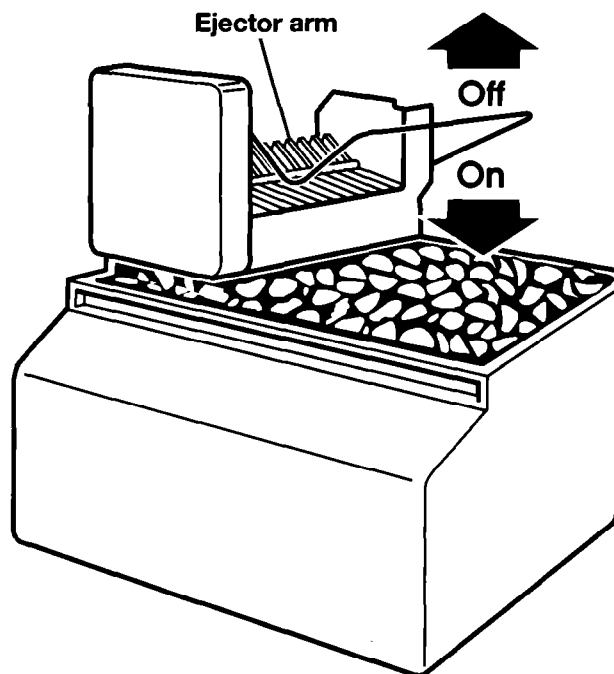

## REMOVING THE ICE MAKER STORAGE BIN

There are several reasons why you may need to remove, empty, and clean the ice maker storage bin.

- The ice dispenser has not, or will not, be used for a week or more.
- A power failure causes the ice in the bin to melt and freeze together.
- The ice dispenser is not used regularly.
- Ice tastes off-flavored. (See Troubleshooting guide on page 37.)

If any of these conditions apply to you, follow the instructions on removing the ice bin.

### To remove the ice bin:

1. Pull the covering panel out from the bottom and then slide it back toward the rear.

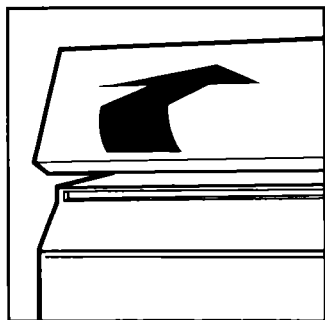

2. Lift the signal arm so it clicks into the OFF (up) position. Ice can still be dispensed, but no more can be made.

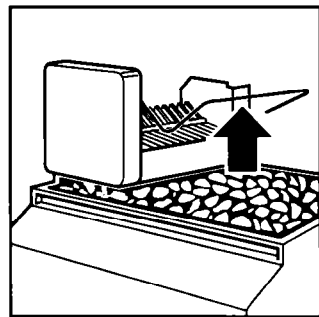

3. Lift up the front of the storage bin and pull it out.

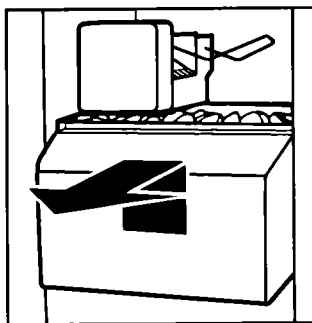

4. Empty the ice bin. Use hot or warm water to melt the ice if necessary. **Never use anything sharp** to break up the ice in the bin. This can cause damage to the bin and the dispenser mechanism.
5. Wash with a mild detergent and rinse well. Do not use harsh or abrasive cleaners or solvents.

**When you replace the bin,** make sure it is pushed in all the way or the dispenser will not work. Then push the signal arm down to the ON position to restart ice production. Make sure the door is closed tightly.

# CHANGING THE LIGHT BULBS

## ⚠ WARNING



### Electrical Shock Hazard

**Unplug the refrigerator before removing a light bulb.**

**Failure to do so can result in death or electrical shock.**

Your refrigerator has several light bulbs. This section shows you where they are located and tells you how to change them if they burn out. Before you change any light bulb in your refrigerator, be sure to turn the Refrigerator Control to OFF and unplug the refrigerator. After you have replaced the bulb, plug the refrigerator in and reset the Refrigerator Control to the desired setting.

**NOTE:** Not all commercial appliance bulbs will fit your refrigerator. Be sure to replace the bulb with one of the same size and shape.

### To change the refrigerator light:

1. Reach behind the Control Panel and remove the bulb.
2. Replace the bulb with a 40-watt appliance bulb.

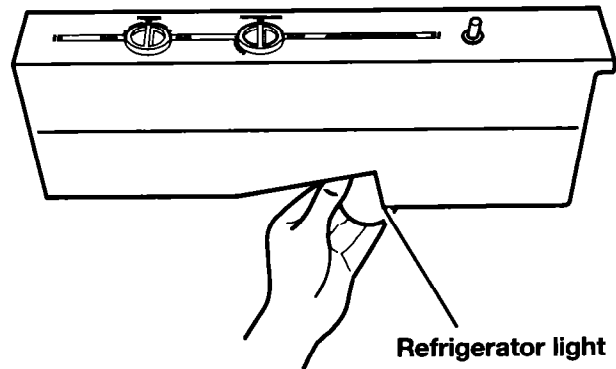

Refrigerator light

### To change the crisper light:

1. Pull the top of the light shield forward until it snaps free and lower until the light bulb is visible.
2. Replace the bulb with a 40-watt appliance bulb.
3. Pull the top of the light shield up over the bulb and snap it onto the side wall supports.

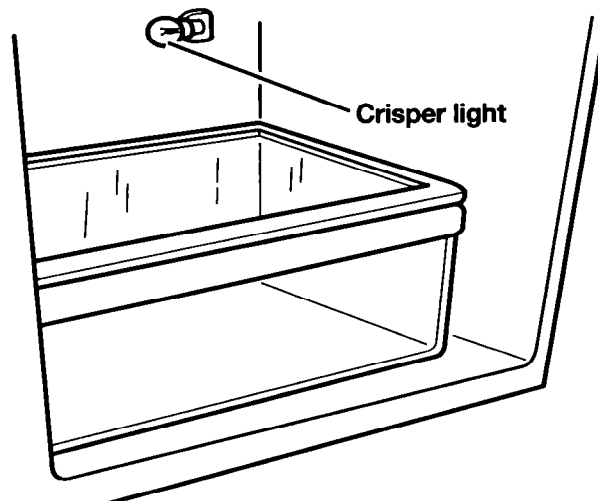

Crisper light

**NOTE:** To remove light shield for cleaning, remove the crisper and the crisper cover. Then release the bottom of the shield from the lower side wall supports. Pull the light shield out from above the crisper cover and wash it with warm water and a liquid detergent. Dry the cover and replace it in the reverse order.

## CHANGING THE LIGHT BULBS (CONT.)

### To change the light below the ice bin:

1. Push in the sides of the light shield and pull down until the shield snaps free.
2. Replace the bulb with a 40-watt appliance bulb.
3. Replace the light shield.

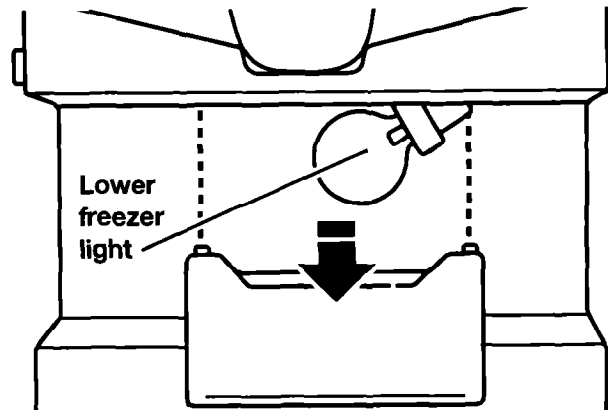

### To change the upper freezer light (on some models):

1. Remove the light shield by grasping the top center of the shield and pulling forward while turning it slightly to one side.
2. Replace the bulb with a 40-watt appliance bulb.
3. To replace the light shield:
  - Grasp the top center of the shield and insert the tabs on one end into the slotted holes in the freezer liner.
  - Carefully bend the shield at the center to insert the tabs on the other end.

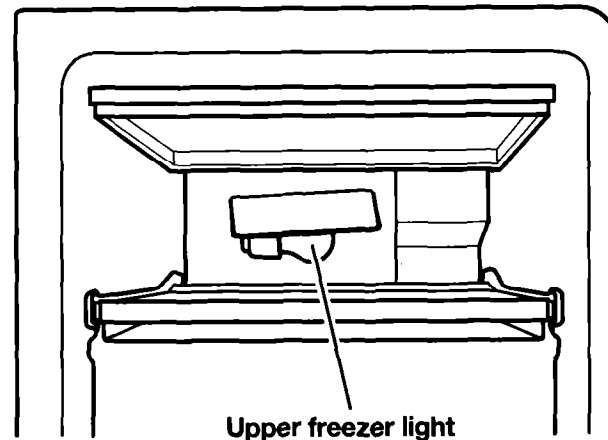

### To change the dispenser area light:

1. Reach through the dispenser area to remove the bulb.
2. Replace the bulb with a heavy-duty 10-watt bulb, which can be purchased from your Whirlpool dealer.

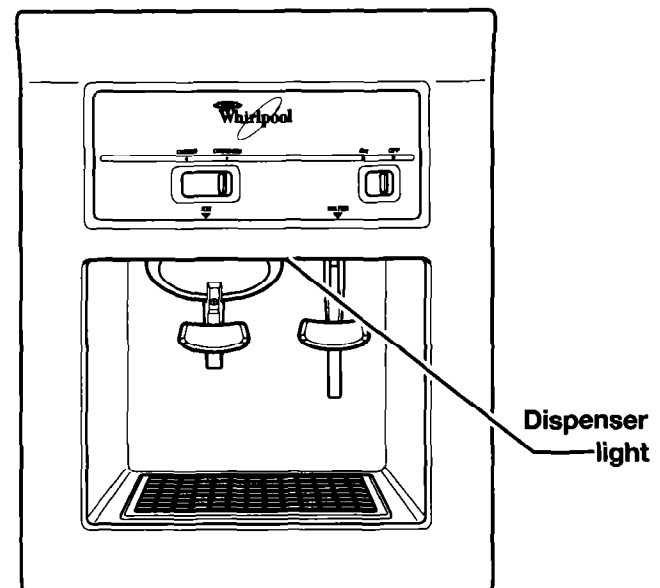

## **UNDERSTANDING THE SOUNDS YOU MAY HEAR**

Your new refrigerator may make sounds that your old one didn't make. Because the sounds are new to you, you might be concerned about them. Most of the new sounds are normal. Hard surfaces, like the floor, walls, and cabinets can make the sounds seem louder than they actually are. Due to new product designs, there may be sounds that you are not familiar with. The following describes the kinds of sounds that might be new to you, and what may be making them.

- Your refrigerator is designed to run more efficiently to keep your food items at the desired temperature. The high efficiency compressor may cause your new refrigerator to run longer than your old one, and you may hear a pulsating or high pitched sound.
- Water dripping on the defrost heater during a defrost cycle may cause a sizzling sound.
- If your product is equipped with an ice maker, you will hear a buzzing sound when the water valve opens to fill the ice maker for each cycle.
- You may hear the evaporator fan motor circulating the air through the refrigerator and freezer compartments.
- As each cycle ends, you may hear a gurgling sound due to the refrigerant equalizing in your refrigerator.
- The defrost timer will click when the automatic defrost cycle begins and ends.
- The thermostat, refrigerator control, will click when cycling on and off.
- Rattling noises may come from the flow of refrigerant, the waterline, or items stored on top of the refrigerator.
- Contraction and expansion of the inside walls may cause a popping and cracking noise.

## **SAVING ENERGY**

There are ways that you can help your refrigerator run more efficiently.

- Check the door gaskets for a tight seal. Leveling the cabinet will ensure a proper seal.
- Clean the condenser coils regularly. A coil cleaning brush is available for purchase (part number 4210463).
- Open the door as few times as possible.
- Don't block the air vents in the freezer and refrigerator so that cold air cannot flow freely. (see page 13.)
- Do not set your refrigerator and freezer at a colder setting than is needed. Keep the refrigerator control at the lowest number setting that keeps your ice cream firm and your drinks as cold as you like.
- Do not put your refrigerator next to a heat source, such as a range, water heater, furnace, radiator, or in direct sunlight.

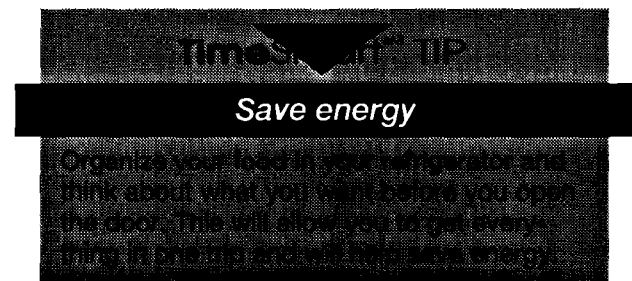

# CARING FOR YOUR REFRIGERATOR

Your refrigerator is built to give you many years of dependable service. However, there are a few things you can do to help extend its product life. This section tells you how to clean your refrigerator and what to do when going on vacation, moving, or during a power outage.

## CLEANING YOUR REFRIGERATOR

Both the refrigerator and freezer sections defrost automatically. However, clean both about once a month to help prevent odors from building up. Wipe up spills right away.



To clean your refrigerator, turn the Refrigerator Control to OFF, unplug it, take out all removable parts, and clean the refrigerator according to the following directions.

### ⚠ WARNING



#### Burn Hazard

Do not touch refrigeration tubes near defrost pan.

Doing so can result in burns.

PART	WHAT TO USE	HOW TO CLEAN
<b>Removable parts</b> (shelves, crisper, etc.)	Sponge or cloth with mild detergent and warm water	<ul style="list-style-type: none"> <li>● Hand wash, rinse, and dry thoroughly.</li> </ul>
<b>Outside</b>	Sponge, cloth, or paper towel with mild detergent, warm water, and a good appliance wax (or good auto paste wax)	<ul style="list-style-type: none"> <li>● Wash outside of cabinet. Do not use abrasive or harsh cleaners.</li> <li>● Wipe and dry thoroughly.</li> <li>● Wax painted, metal surfaces at least twice a year. Apply wax with a clean, soft cloth. <b>Waxing exterior painted, metal surfaces helps provide rust protection. Do not get wax on plastic parts or gaskets.</b></li> </ul>
<b>Inside walls</b> (allow freezer to warm up so cloth won't stick)	Sponge or soft cloth with baking soda or mild detergent and warm water	<ul style="list-style-type: none"> <li>● Wash with mixture of warm water and:                             <ul style="list-style-type: none"> <li>– mild detergent, or</li> <li>– baking soda (2 tbs to 1 qt [about 25 g to 1L] of water).</li> </ul> </li> <li>● Wipe and dry thoroughly.</li> </ul>
<b>Door liners and gaskets</b>	Sponge or soft cloth with mild detergent and warm water	<ul style="list-style-type: none"> <li>● Wash, wipe, and dry thoroughly.</li> </ul> <p><b>DO NOT USE cleaning waxes, concentrated detergents, bleaches, or cleaners containing petroleum on plastic parts or gaskets.</b></p>
<b>Plastic parts</b> (covers and panels)	Sponge or soft cloth with mild detergent and warm water	<ul style="list-style-type: none"> <li>● Wash, wipe, and dry thoroughly.</li> </ul> <p><b>DO NOT USE paper towels, window sprays, scouring cleansers, or flammable fluids. These can scratch or damage plastic parts. See "Important Safety Instructions" on page 3.</b></p>

continued on next page

## CLEANING YOUR REFRIGERATOR (CONT.)

PART	WHAT TO USE	HOW TO CLEAN
<b>Defrost pan</b>	Sponge or cloth with mild detergent and warm water	<ul style="list-style-type: none"> <li>● Remove base grille. (See below.)</li> <li>● Reach into small opening at left edge and remove the defrost pan.</li> <li>● Wash, rinse, and dry thoroughly.</li> <li>● Replace defrost pan. Make sure to push it completely into the opening.</li> <li>● Replace base grille.</li> </ul>
<b>Condenser coils</b>	Vacuum cleaner with extended narrow attachment	<ul style="list-style-type: none"> <li>● Remove base grille.</li> <li>● Vacuum coils when dusty or dirty. Coils may need to be cleaned as often as every other month.</li> <li>● Replace base grille.</li> </ul>

## REMOVING THE BASE GRILLE

The base grille can be easily removed for access to the defrost pan and condenser coils. You will need to remove the base grille to clean the defrost pan or the condenser coils (see above).

### To remove the base grille:

1. Open both doors.
2. Place hands along the ends of the grille, with your thumbs along the top. Push in with your thumbs and pull up on the bottom.

**NOTE:** Do not remove the Tech Sheet that is fastened behind the grille.

### To replace the grille:

1. Line up the grille support tabs with the metal clips.
2. Push the grille firmly to snap it into place and close the doors.

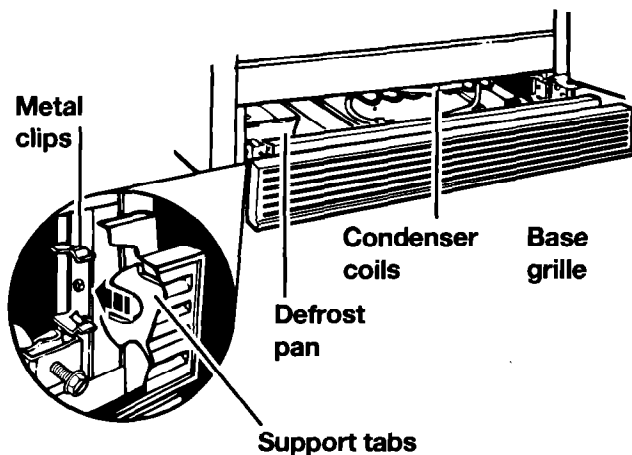

## VACATION AND MOVING CARE

### Short vacations

If you will be away for less than four weeks, there is no need to turn off your refrigerator. Use these tips to prepare your refrigerator before you leave.

1. Use up any perishables and freeze other items.
2. Raise ice maker signal arm to the OFF (up) position and shut off the water supply.
3. Empty the ice bin.

### Long vacations

If you will be gone for a month or more, follow these steps to prepare your refrigerator.

1. Turn off the water supply to the ice maker at least one day ahead of time.
2. When the last load of ice drops, turn off the ice maker and make sure all ice is dispensed out of the ice maker mechanism.
3. Remove all food from your refrigerator.
4. Turn the Refrigerator Control to OFF.
5. Unplug the refrigerator.
6. Remove water that may be in the defrost pan. (See page 33.)
7. Clean it, wipe it, and dry well.
8. To keep the doors propped open far enough for air to get in, tape rubber or wooden blocks to the tops of both doors. This will stop odor and mold from building up.

### Moving

When you are moving your refrigerator to a new home, follow these steps to prepare it for the move.

1. Turn off the water supply to the ice maker at least one day ahead of time.
2. Disconnect the water line from the back of the refrigerator.
3. When the last load of ice drops, lift the signal arm to the OFF (up) position.
4. Remove all food from the refrigerator and pack all frozen food in dry ice.
5. Turn the Refrigerator Control to OFF.
6. Unplug the refrigerator.
7. Empty water from the defrost pan.
8. Clean, wipe, and dry the entire product well.
9. Take out all removable parts, wrap them well, and tape them together so they don't shift and rattle during the move.
10. Screw in the leveling rollers.
11. Tape the doors shut and the power cord to the refrigerator cabinet.

When you get to your new home, put everything back and see page 7 for preparation instructions. Also, if your refrigerator has an automatic ice maker, remember to reconnect the home water source to the refrigerator.

## POWER INTERRUPTIONS

If the electricity in your house goes off, call the power company and ask how long it will be off.

1. If the power will be out for 24 hours or less, **keep both doors closed** to help foods stay cold and frozen.
2. If the power will be out for more than 24 hours:
  - (a) Remove all frozen food and store it in a frozen food locker.

**OR**

- (b) Place 2 lb. (900 g) of dry ice in the freezer for every cubic foot (liter) of freezer space. This will keep the food frozen for two to four days. While handling dry ice, wear gloves to protect your hands from ice burns.

**OR**

- (c) If neither a food locker or dry ice is available, use up or can perishable food at once.

**REMEMBER:** A full freezer stays cold longer than a partly filled one. A freezer full of meat stays cold longer than a freezer full of baked goods. If food contains ice crystals, it may be safely refrozen, although the quality and flavor may be affected. If the condition of the food is poor, or if you feel it is unsafe, dispose of it.

### Questions?

Call our Consumer Assistance Center telephone number, **1-800-253-1301**, from anywhere in the U.S.A.

# FOOD STORAGE GUIDE

There is a correct way to package and store refrigerated or frozen food. To keep food fresher, longer, take the time to study these recommended steps.

## STORING FRESH FOOD

Wrap or store food in the refrigerator in airtight and moisture-proof material unless otherwise noted. This prevents food odor and taste transfer throughout the refrigerator. For dated products, check code date to ensure freshness.

### Leafy vegetables

Remove store wrapping and trim or tear off bruised and discolored areas. Wash in cold water and drain. Place in plastic bag or plastic container and store in crisper.

### Vegetables with skins

(carrots, peppers)

Store in crisper, plastic bags, or plastic container.

### Fruit

Wash, let dry, and store in refrigerator in plastic bags or crisper. Do not wash or hull berries until they are ready to use. Sort and keep berries in original container in a crisper, or store in a loosely closed paper bag on a refrigerator shelf.

### Eggs

Store without washing in original carton on interior shelf.

### Milk

Wipe milk cartons. For best storage, place milk on interior shelf.

### Butter or margarine

Keep opened butter in covered dish or closed compartment. When storing an extra supply, wrap in freezer packaging and freeze.

### Cheese

Store in the original wrapping until you are ready to use it. Once opened, rewrap tightly in plastic wrap or aluminum foil.

### Leftovers

Cover leftovers with plastic wrap or aluminum foil. Plastic containers with tight lids can also be used.

### Meat

Store most meat in original wrapping as long as it is airtight and moisture-proof. Rewrap if necessary. See the following for storage times. When storing meat longer than the times given, freeze the meat.

Chicken .....	1-2 days	Bacon .....	5-7 days
Ground beef .....	1-2 days	Cold cuts .....	3-5 days
Steaks/roasts ...	3-5 days	Variety meats ...	1-2 days
Cured meats ...	7-10 days		

### Fish

Use fresh fish and shellfish the same day as purchased.



## STORING FROZEN FOOD

The freezer section is designed for storage of commercially frozen food and for freezing food at home.

**NOTE:** For further information about preparing food for freezing or food storage times, check a freezer guide or reliable cookbook.

### Packaging

The secret of successful freezing is in the packaging. The way you close and seal the package must not allow air or moisture in or out. Packaging done in any other way could cause food odor and taste transfer throughout the refrigerator and drying of frozen food.

#### Packaging recommended for use:

- Rigid plastic containers with tight-fitting lids
- Straight-sided canning/freezing jars
- Heavy-duty aluminum foil
- Plastic-coated paper
- Non-permeable plastic wraps (made from saran film)
- Specified Freezer self-sealing plastic bags

Follow package or container instructions for proper freezing methods.

#### Do not use:

- Bread wrappers
- Non-polyethylene plastic containers
- Containers without tight lids
- Wax paper
- Wax-coated freezer wrap
- Thin, semi-permeable wrap

The use of these wrappings could cause food odor, taste transfer, and drying of frozen food.

### Freezing

Do not expect your freezer to quick-freeze any large quantity of food. Put no more unfrozen food into the freezer than will freeze within 24 hours (no more than two to three lbs of food per cubic foot [907-1,350 g per liter] of freezer space). Leave enough space for air to circulate around packages. Be careful to leave enough room at the front so the door can close tightly.

Storage times will vary according to the quality and type of the food, the type of packaging or wrap used, (airtight and moisture-proof), and the storage temperature.

Ice crystals inside a sealed package are normal. This simply means that moisture in the food and air inside the package has condensed, creating ice crystals.

TimesSmart TIP

#### Save Energy

Allow hot foods to cool at room temperature for 30 minutes, then package and freeze. Cooling hot foods before freezing will save energy.

# TROUBLESHOOTING GUIDE

You can solve many common refrigerator problems easily, saving you the cost of a possible service call. Try the suggestions below to see if you can solve your problem without outside help. If the suggestions do not work, please call the Whirlpool Consumer Assistance Center toll-free from anywhere in the U.S. at 1-800-253-1301.

## YOUR REFRIGERATOR WILL NOT OPERATE

Check if...	Then...
The power supply cord is unplugged.	Firmly plug the cord into a live outlet with proper voltage.
A household fuse has blown or circuit breaker has tripped.	Replace the fuse or reset the circuit.
The refrigerator control is turned to the "OFF" position.	See "Setting the controls" on page 12.
The refrigerator is defrosting.	Recheck to see if the refrigerator is operating in 30 minutes. Your refrigerator will regularly run an automatic defrost cycle.  If it is still not running after checking the above items, call the Consumer Assistance Center at 1-800-253-1301.

## THE LIGHTS DO NOT WORK

Check if...	Then...
The power supply cord is unplugged.	Firmly plug the cord into a live outlet with proper voltage.
A household fuse or circuit breaker has tripped.	Replace the fuse or reset the circuit.
A light bulb is loose in the socket.	Turn the Refrigerator Control to OFF.  Disconnect the refrigerator from the electrical supply. Gently remove the bulb and reinsert. Then reconnect the refrigerator to the electrical supply and reset the refrigerator Control.
A light bulb has burned out.	Replace with an appliance bulb of the same wattage, size, and shape. See "Changing the light bulbs" on pages 24 and 25.

## THERE IS WATER IN THE DEFROST DRAIN PAN

Check if...	Then...
The refrigerator is defrosting.	The water will evaporate. It is normal for water to drip into the defrost pan.
It is more humid than normal.	Expect that the water in the defrost pan will take longer to evaporate. This is normal when it is hot or humid.
Water in the defrost pan is overflowing.	Check to make sure your refrigerator is level. (See "Leveling it" on page 8.) If it is still overflowing there is probably something wrong with the refrigerator. Call the Consumer Assistance Center at 1-800-253-1301.

## THE MOTOR SEEMS TO RUN TOO MUCH

Check if...	Then...
The room temperature is hotter than normal.	Expect the motor to run longer under warm conditions. At normal room temperatures, expect your motor to run about 40% to 80% of the time. Under warmer conditions, expect it to run even more of the time.
A large amount of food has just been added to the refrigerator.	Adding a large amount of food warms the refrigerator. It is normal for the motor to run longer in order to cool the refrigerator back down. See "Food storage" on page 30.
The door is opened often.	Expect the motor to run longer when this occurs. In order to conserve energy, try to get everything you need out of the refrigerator at once, keep food organized so it is easy to find, and close the door as soon as the food is removed.
The controls are not set correctly for the surrounding conditions.	See "How the controls work" on page 12.
The doors are not closed completely.	Push the doors firmly shut. If they will not shut all the way, see "The doors will not close completely," on page 38.
The doors are misaligned.	See "Leveling it" on page 8 or call the Consumer Assistance Center at 1-800-253-1301.
The base grille is dirty or blocked.	This prevents air circulation and makes the motor work harder. Remove the grille and clean. See "Removing the base grille" on page 28.
The condenser coils are dirty.	This prevents air transfer and makes the motor work harder. Clean the condenser coils. See "Cleaning your refrigerator" on page 28.
	If the problem is not due to any of the above, remember that your new refrigerator will run longer than your old one due to its high efficiency motor.

## THE ICE MAKER IS NOT PRODUCING ICE

Check if...	Then...
The freezer temperature is not cold enough to produce ice.	See "Setting the controls" on page 12.
The ice maker arm is in the "OFF" (up) position.	Lower arm to the "ON" (down) position. See "Using the automatic ice maker" on page 22.
The water line shut-off valve to the refrigerator is not turned on.	Turn on the water valve. See "Attaching the ice maker to a water supply" on pages 9-11. If not due to any of the above, there may be a problem with the water line. Contact the Consumer Assistance Center at 1-800-253-1301.
An ice cube is jammed in the ejector arm.	Remove the ice from the ejector arm with a plastic utensil. See page 22 for ejector arm location.
The ice maker mold has no water in it or no ice has been produced.	Check to see if your refrigerator has been connected to your home water supply and the supply shut-off valve is turned on. See "Attaching the ice maker to a water supply" on pages 9-11.

## THE ICE MAKER IS PRODUCING TOO LITTLE ICE

Check if...	Then...
The ice maker has just been installed.	Wait 72 hours for full ice production to begin. Once your refrigerator is cooled down, the ice maker should begin producing 70-120 cubes every 24 hours.
A large amount of ice has just been removed.	Allow 24 hours for ice maker to restock.
The controls are not set correctly.	See "Setting the controls" on page 12.
The water shut-off valve is not turned completely on.	Turn valve on fully. See "Attaching the ice maker to a water supply" on pages 9-11.
There is a water filter installed on the refrigerator. This filter may be clogged or installed incorrectly.	First, check the filter installation instructions to ensure that the filter was installed correctly and is not clogged. If installation or clogging is not a problem, call the Consumer Assistance Center at 1-800-253-1301.

## THE ICE DISPENSER WILL NOT OPERATE PROPERLY

Check if...	Then...
The freezer door is not closed completely.	Push the door firmly shut. If it will not shut all the way, see "The doors will not close completely" on page 38.
The ice bin is not installed correctly.	Push the ice bin in all the way. If the ice bin does not go in all the way, it may not be put in straight. Pull it out and try again.
The wrong ice has been added to the bin.	Use only cubes produced by the current ice maker. If other cubes have been added, remove all cubes and check to see that none have become stuck in the delivery chute.
The ice has frozen in the ice bin.	Shake the ice bin to separate cubes. If cubes do not separate, empty bin and wait 24 hours for ice to restock.
The ice has melted around the auger (metal spiral) in the ice bucket.	Dump the ice cubes and clean the ice bucket completely. Allow 24 hours for the ice maker to re-stock. Do not try to remove the melted ice with a sharp object. You could damage the ice bucket.
Ice is stuck in the delivery chute.	Clear the ice from the delivery chute with a plastic utensil. Do not use anything sharp to remove the ice. You could cause damage.
There is no ice in the bucket.	See "The ice maker is not producing ice" on page 34.
The dispenser arm has been held in too long.	Release dispenser arm. Ice will stop dispensing when the arm is held in too long. Wait three minutes for dispenser motor to reset before using again. (For future use, take large amounts of ice directly from the ice maker so that the dispenser arm is not held in too long.)

## THE WATER DISPENSER WILL NOT OPERATE PROPERLY

Check if...	Then...
The freezer door is not closed completely.	Push the door firmly shut. If it will not shut all the way, see "The doors will not close completely" on page 38.
The water tank has not filled.	The water tank needs to be filled the first time it is used. Depress the water dispenser bar with a large container until you draw two or three quarts (1.9 to 2.8 L) of water. Discard water. (Refer to page 21 for further instructions on filling the water tank.)
The water shut-off valve is not turned on or the water line is not connected at the source.	Check to be sure the water shut-off valve is turned on and the water source is connected to the refrigerator. Refer to pages 9 and 10 for directions.
The water shut-off valve is clogged or incorrectly installed.	Refer to pages 9 and 10. Call the Consumer Assistance Center at 1-800-253-1301 or a plumber.
There is a kink in the home water source line.	If you find or suspect a kink in the water line, call the Consumer Assistance Center at 1-800-253-1301.
There is a water filter installed on the refrigerator. This filter may be clogged or incorrectly installed.	First, check the filter installation instructions to ensure that the filter was installed correctly and is not clogged. If installation or clogging is not a problem, call the Consumer Assistance Center at 1-800-253-1301.

## WATER OR ICE IS LEAKING FROM THE DISPENSER

Check if...	Then...
The glass is not being held under the ice dispenser long enough, causing the ice to spill.	Hold the container under the ice chute for two to three seconds after releasing the dispenser lever. A small amount of ice may dispense after the lever is released.
The glass is not being held under the water dispenser long enough, causing water to drip.	Hold the container under the water dispenser two to three seconds after releasing the dispenser lever. Water may continue to dispense during this time.
An ice cube is stuck in the chute and holding the trap door open.	Remove the cube.

## THE DISPENSER WATER IS NOT COOL ENOUGH

Check if...	Then...
The refrigerator has been newly installed.	Allow 24 hours for the tank to cool completely.
A large amount of water has been recently dispensed.	Allow 24 hours for the tank to cool completely.
No water has been recently dispensed.	The first glass of water may not be cool. Discard the first glass of water.

## OFF-TASTE OR ODOR IN THE ICE

Check if...	Then...
The plumbing connections are new, causing discolored or off-flavored ice.	Discard the first few batches of ice.
The ice cubes have been stored for too long.	Throw old ice away and make a new supply.
Food in the freezer has not been wrapped properly.	See page 31 for food storage instructions.
Freezer and ice bin need to be cleaned.	See page 27 for cleaning instructions.
Water contains minerals (such as sulfur).	A filter may need to be installed to remove the minerals.

## THE CENTER DIVIDER BETWEEN THE TWO COMPARTMENTS IS WARM

Check if...	Then...
The condenser coil or base grille is dirty or clogged.	Clean according to the directions on page 28.
	If not due to any of above, the warmth is probably due to normal operation of the automatic exterior moisture control. If still concerned, call the Consumer Assistance Center at 1-800-253-1301.

## TEMPERATURE IS TOO WARM

Check if...	Then...
The air vents are blocked in either compartment. This prevents the movement of cold air from the freezer to the refrigerator.	Remove any objects from in front of the air vents. Refer to page 13 for the location of air vents.
The door(s) are opened often.	Be aware that the refrigerator will warm when this occurs. In order to keep the refrigerator cool, try to get everything you need out of the refrigerator at once, keep food organized so it is easy to find, and close the door as soon as the food is removed.
A large amount of food has just been added to the refrigerator or freezer.	Adding a large amount of food warms the refrigerator. It can take several hours for the refrigerator to return to the normal temperature.
The controls are not set correctly for the surrounding conditions.	See "How the controls work" on page 12.

## THERE IS INTERIOR MOISTURE BUILD-UP

Check if...	Then...
The air vents are blocked in the refrigerator.	Remove any objects from in front of the air vents. Refer to page 13 for the location of air vents.
The door is opened often.	To avoid humidity build-up, try to get everything you need out of the refrigerator at once, keep food organized so it is easy to find, and close the door as soon as the food is removed. (When the door is opened, humidity from the outside air enters the refrigerator. The more often the door is opened, the faster humidity builds up, especially when the room itself is very humid.)
The room is humid.	It is normal for moisture to build up inside the refrigerator when the outside air is humid.
The food is not packaged correctly.	Check that all food is securely wrapped. If necessary, repackage food according to the guidelines on page 30, the "Food Storage Guide." Wipe off damp food containers before placing in the refrigerator.
The controls are not set correctly for the surrounding conditions.	See "How the controls work" on page 12.
A self defrost cycle was completed.	It is normal for droplets to form on the back wall after the refrigerator self-defrosts.

## THE DOORS WILL NOT CLOSE COMPLETELY

Check if...	Then...
Food packages are blocking the door open.	Rearrange containers so that they fit more tightly and take up less space.
The ice bin is out of position.	Push the ice bin in all the way.
The pans, shelves, bins, or baskets are out of position.	Put all pans, shelves, bins, and baskets back into their correct position.
The gaskets are dirty.	Clean gaskets according to the directions on page 27.
The refrigerator is not level.	Level the refrigerator. Refer to "Leveling it" on page 8.
The doors were removed during product installation and not properly replaced.	Remove and replace the doors according to the removal instructions that came with your refrigerator. Or, call the Consumer Assistance Center at 1-800-253-1301.

## THE DOORS ARE DIFFICULT TO OPEN

Check if...	Then...
The gaskets are dirty or sticky.	Clean gaskets according to the directions on page 27.

# REQUESTING ASSISTANCE OR SERVICE

To avoid unnecessary service calls, please check the "Troubleshooting Guide" on pages 32-38. It may save you the cost of a service call. If you still need help, follow the instructions below.

## IF YOU NEED ASSISTANCE OR SERVICE

**Call the Whirlpool Consumer Assistance Center toll free at 1-800-253-1301. Our consultants are available to assist you 24 hours a day, 7 days a week.**



When calling:

Please know the purchase date, and the complete model and serial number of your appliance (see page 2). This information will help us better respond to your request.

**Our consultants provide assistance with:**

- Features and specifications on our full line of appliances
- Installation information
- Use and maintenance procedures

- Accessory and repair parts sales
- Do-it-yourself repair help
- Specialized customer assistance (Spanish speaking, hearing impaired, limited vision, etc.)
- Referrals to local dealers, service companies, and repair parts distributors

**Whirlpool service technicians** are trained to fulfill the product warranty and provide after-warranty service, anywhere in the United States.

To locate the authorized Whirlpool service company in your area, you can also look in your telephone directory Yellow Pages.

## IF YOU NEED REPLACEMENT PARTS

If you need to order replacement parts, we recommend that you only use FSP® factory authorized parts. FSP replacement parts will fit right and work right, because they are made to the same exacting specifications used to build every new WHIRLPOOL appliance.

To locate FSP replacement parts in your area, call our Consumer Assistance Center telephone number or your nearest authorized service center.

## FOR FURTHER ASSISTANCE

If you need further assistance, you can write to Whirlpool with any questions or concerns at:

Whirlpool Brand Home Appliances  
Consumer Assistance Center  
c/o Correspondence Dept.  
414 N. Peters Rd.  
Knoxville, TN 37922

Please include a daytime phone number in your correspondence.

If the dealer, authorized servicer, and Whirlpool have failed to resolve your problem, you can contact the Major Appliance Consumer Action Program (MACAP). MACAP is a group of independent consumer experts that voice consumer views at the highest levels of the major appliance industry. MACAP will in turn inform us of your action.

Major Appliance Consumer Action Program  
20 North Wacker Drive  
Chicago, IL 60606

# INDEX

This index is alphabetical. It contains all the topics included in this manual, along with the pages on which you can find each topic.

TOPIC	PAGE	TOPIC	PAGE
AIR CIRCULATION .....	13	PARTS AND FEATURES .....	4-6
BASE GRILLE		POWER INTERRUPTIONS .....	29
Removing .....	28	REFRIGERATOR SECTION	
CLEANING		Door bins .....	14
How to .....	27	Door trim .....	14
Moving .....	29	Crisper .....	18
Vacation .....	29	Crisper cover .....	18
CONTROLS		Meat drawer .....	15
How they work .....	12	Snack bin .....	19
Setting .....	12	SAFETY .....	3
DISPENSERS .....	20-22	SERVICE	
Ice dispenser .....	20	Requesting .....	39
Light .....	22, 25	SOUNDS	
Water dispenser .....	21	Understanding .....	26
FOOD STORAGE		STORAGE	
Freezing .....	31	Moving .....	29
Fresh Food .....	30	Vacation .....	29
FREEZER SECTION		TEMPERATURE	
Baskets .....	19	Controlling .....	12
Shelves .....	19	Meat drawer .....	17
ICE MAKER		TROUBLESHOOTING .....	32-38
Attaching to a water supply .....	9-11	WARRANTY .....	44
Removing storage bin .....	23		
Using .....	22		
LIGHT BULBS			
Changing .....	24, 25		

# WARRANTY

## WHIRLPOOL® REFRIGERATOR

LENGTH OF WARRANTY	WHIRLPOOL WILL PAY FOR
<b>FULL ONE-YEAR WARRANTY</b> From Date of Purchase	FSP® replacement parts and repair labor to correct defects in materials or workmanship. Service must be provided by an authorized Whirlpool service company.
<b>FULL FIVE-YEAR WARRANTY</b> From Date of Purchase	FSP replacement parts and repair labor to correct defects in materials or workmanship in the sealed refrigeration system. These parts are: <ol style="list-style-type: none"> <li>1. Compressor</li> <li>2. Evaporator</li> <li>3. Condenser</li> <li>4. Drier</li> <li>5. Connecting tubing</li> </ol> Service must be provided by an authorized Whirlpool service company.
<b>WHIRLPOOL WILL NOT PAY FOR</b>	
<p><b>A. Service calls to:</b></p> <ol style="list-style-type: none"> <li>1. Correct the installation of your refrigerator.</li> <li>2. Instruct you how to use your refrigerator.</li> <li>3. Replace house fuses or correct house wiring or plumbing.</li> <li>4. Replace light bulbs.</li> </ol> <p><b>B. Repairs when your refrigerator is used in other than normal, single-family household use.</b></p> <p><b>C. Pickup and delivery. Your refrigerator is designed to be repaired in the home.</b></p> <p><b>D. Damage to your refrigerator caused by accident, misuse, fire, flood, acts of God, or use of products not approved by Whirlpool.</b></p> <p><b>E. Any food loss due to product failure.</b></p> <p><b>F. Repairs to parts or systems caused by unauthorized modifications made to the appliance.</b></p>	

6/94

WHIRLPOOL CORPORATION SHALL NOT BE LIABLE FOR INCIDENTAL OR CONSEQUENTIAL DAMAGES. Some states do not allow the exclusion or limitation of incidental or consequential damages, so this exclusion or limitation may not apply to you. This warranty gives you specific legal rights, and you may also have other rights which vary from state to state.

**Outside the United States, a different warranty may apply. For details, please contact your authorized Whirlpool dealer.**

If you need service, first see the "Troubleshooting" section of this book. After checking "Troubleshooting," additional help can be found by checking the "Requesting Assistance or Service" section or by calling our Consumer Assistance Center telephone number, **1-800-253-1301**, from anywhere in the U.S.A.